

NOTE 1: FRONTAGE ROADS ARE PROPOSED ONLY WHERE NEEDED TO REESTABLISH ACCESS AT LOCATIONS WHERE NO OTHER ACCESS CAN BE PROVIDED, AND THE COST OF THE FRONTAGE ROAD IS LESS THAN THE COST OF PURCHASING THE OTHERWISE LANLOCKED PROPERTY.

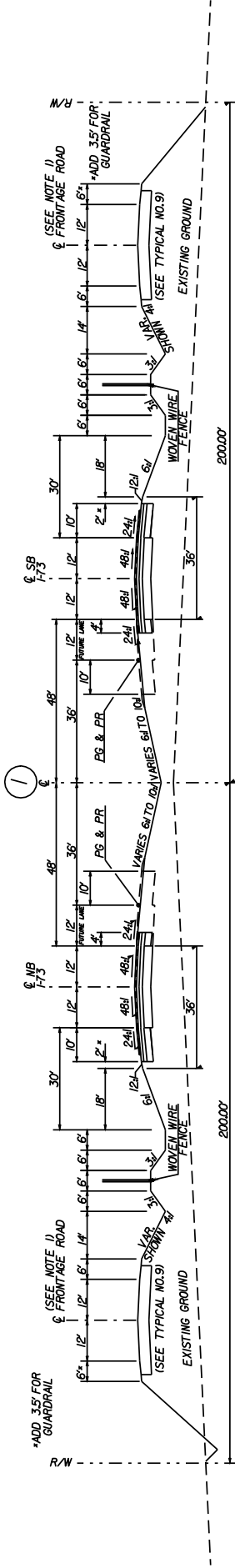

TYPICAL SECTION WITH FRONTAGE ROADS AND SPACE FOR RAILROADS

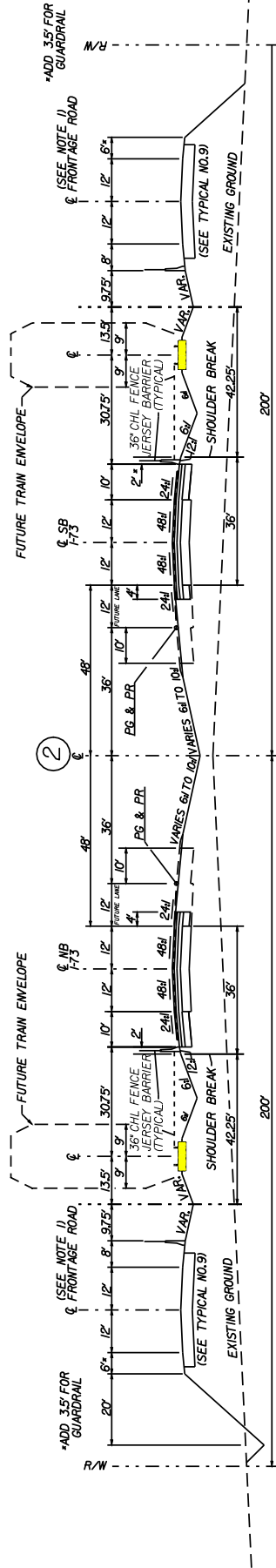

TYPICAL SECTION WITH FRONTAGE ROADS AND RAILROADS



**INTERSTATE 73**  
 DILLON MARION HORRY  
 COUNTIES  
 SOUTH CAROLINA

**CONCEPTUAL ROADWAY PLANS**  
 I-73 SOUTH (I-96 TO S.C. ROUTE 22)

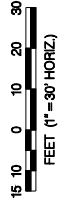

**TYPICAL SECTIONS**  
 WITH FRONTAGE ROADS

**SHEET**  
**2**

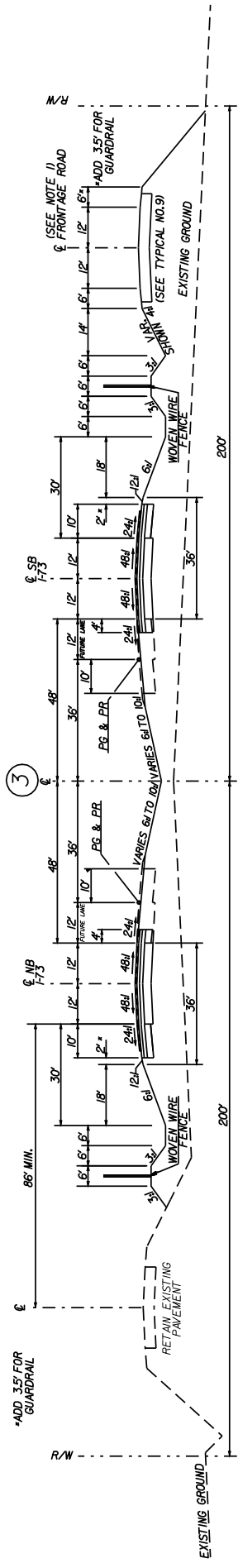

TYPICAL SECTION I-73 USING AN EXISTING ROAD AS A FRONTAGE ROAD

SHEET 2A

TYPICAL SECTIONS WITH FRONTAGE ROADS

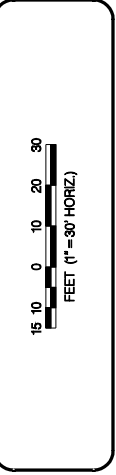

CONCEPTUAL ROADWAY PLANS I-73 SOUTH (I-96 TO S.C. ROUTE 22)

INTERSTATE 73  
 DILLON MARION HORRY  
 COUNTIES  
 SOUTH CAROLINA



EXISTING GROUND

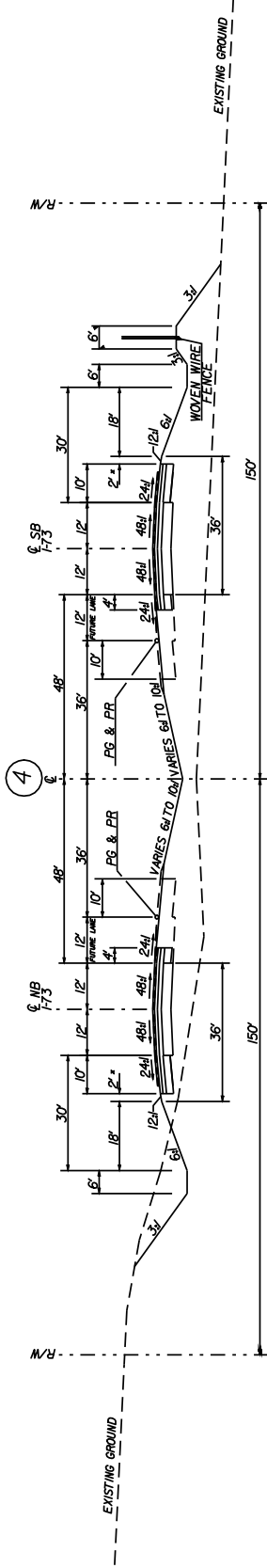

TYPICAL SECTION WITHOUT FRONTAGE ROADS WITH SPACE WITHIN R/W FOR RAILROADS

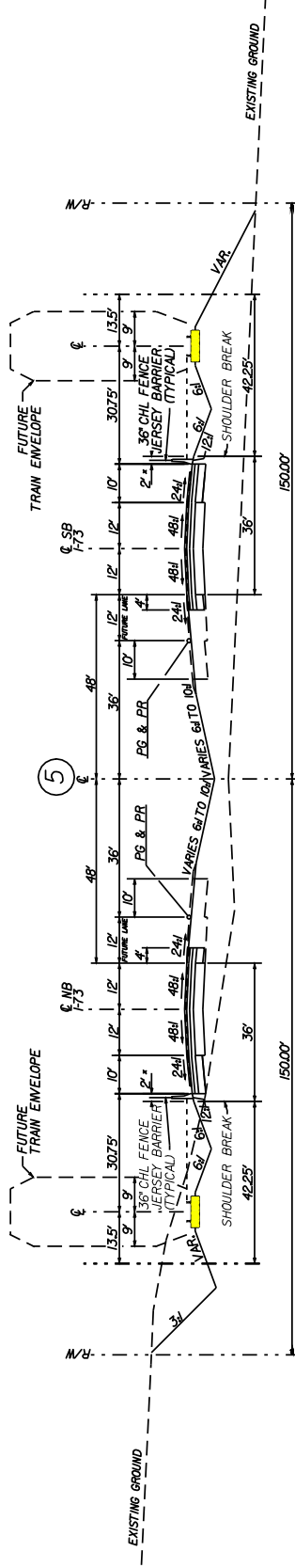

TYPICAL SECTION WITHOUT FRONTAGE ROADS SHOWING RAILROADS WITHIN RIGHT-OF-WAY



INTERSTATE 73  
DILLON MARION HOPPY  
COUNTIES  
SOUTH CAROLINA

CONCEPTUAL ROADWAY PLANS  
I-73 SOUTH (I-96 TO S.C. ROUTE 22)

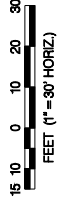

TYPICAL SECTIONS  
WITHOUT FRONTAGE ROADS

SHEET  
2B

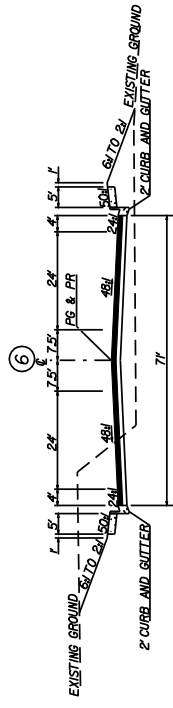

⑥  
TYPICAL FIVE-LANE URBAN STREET  
(CROSS OVER ROAD)  
CURB GUTTER AND SIDEWALK

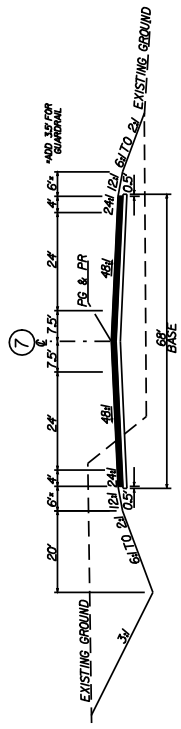

⑦  
TYPICAL FIVE-LANE URBAN STREET  
(CROSS OVER ROAD)  
WITH SHOULDERS

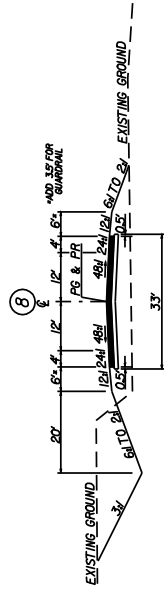

⑧  
TYPICAL TWO-LANE ARTERIALS  
(CROSS OVERS AND RELOCATIONS)

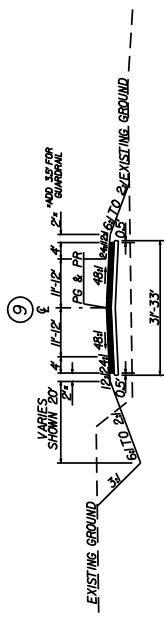

⑨  
TYPICAL TWO-LANE RURAL  
(SIDE AND FRONTAGE ROADS)

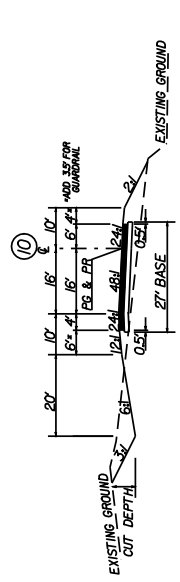

⑩  
ONE-WAY FREEWAY RAMP / LOOP

INTERSTATE 73

0' FILL HEIGHT  
5'-10'  
OVER 10' 24'



INTERSTATE 73  
DILLON MARION HOPPY  
COUNTIES  
SOUTH CAROLINA

CONCEPTUAL ROADWAY PLANS  
I-73 SOUTH (I-96 TO S.C. ROUTE 22)

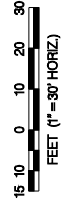

TYPICAL SECTIONS  
OTHER ROADS

SHEET  
2C